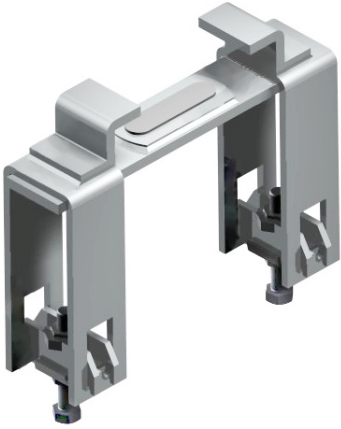
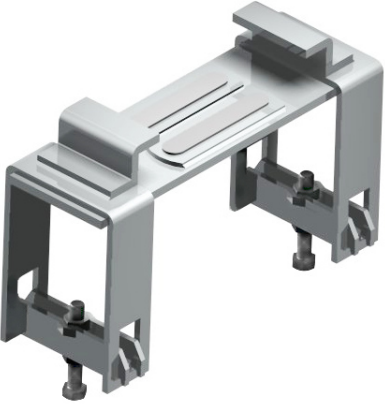

SCREW ON GLIDE PLATEType **302 U-SH**

for beam connections to U-beams

**Selection list for Type 171H and Typ 180 H**

Design	Size	Pipe \varnothing [mm]	Permissible load to bear on [kg]	for U-beam
	1	21.3 - 48.3	800	U 80 - 200 please tell us the beam size
	2	57.0 - 60.3	800	
	3	70.0 - 88.9	800	
	4	108.0 - 139.7	1200	
	5	159.0 - 168.3	1500	
	6	219.1 - 273.0	1800	
	7	323.9 - 457.0	1800	recommend from U 220 please tell us the beam size
	8	508.0	2600	
	9	610.0	2800	
	10	711.0	2800	

Specification

Material No. 1.0038, hot-dip galvanized

Combination possibilities with Type

171 and 180 with retaining profile

Ordering designations: Type...
 e.g. 302 U-SH

Size...
 Size 6

Surface...
 hot-dip galvanized

U-beam...
 U 80